

SECTION 1 GENERAL



Group 1 Safety hints	1-1
Group 2 Specifications	1-5
Group 3 Periodic replacement	1-18

SECTION 1 GENERAL

GROUP 1 SAFETY HINTS

Careless performing of the easy work may cause injuries.

Take care to always perform work safely, at least observing the following.

- Oil is a dangerous substance. Never handle oil, grease or oily clothes in places where there is any fire or flame.

As preparation in case of fire, always know the location and directions for use of fire extinguishers and other fire fighting equipment.

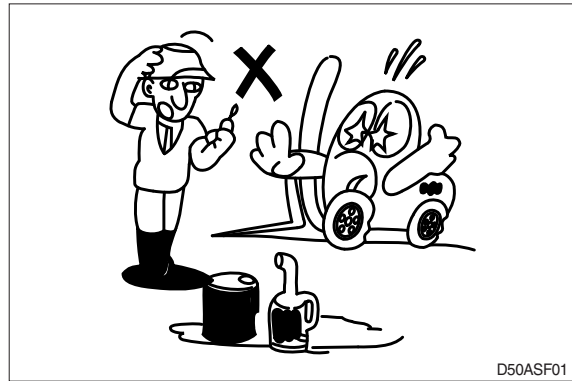

- Wear well-fitting helmet, safety shoes and working clothes. When drilling, grinding or hammering, always wear protective goggles. Always do up safety clothes properly so that they do not catch on protruding parts of truck. Do not wear oily clothes. When checking, always release battery plug.

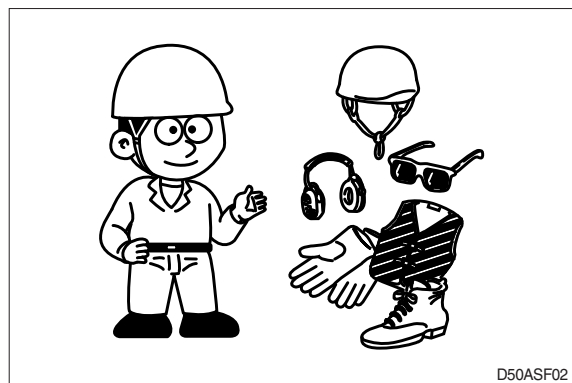

- Flames should never be used instead of lamps. Never use a naked flame to check leaks or the level of oil or electrolyte.

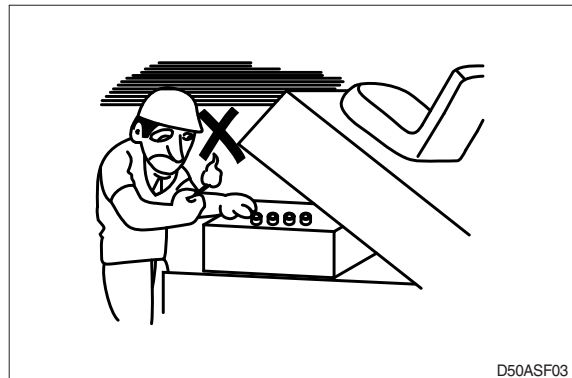

- Exhaust gas is dangerous. Provide adequate ventilation when working in a closed space.

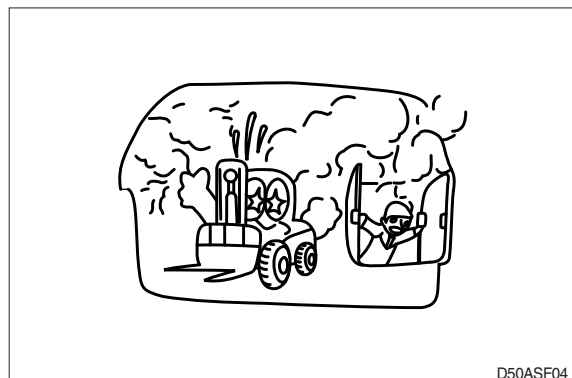

▲ Be particularly careful when removing the radiator cap and the hydraulic oil tank filler cap, if this is done immediately after using the truck, there is a danger that boiled oil may spurt out.

- The procedure for releasing the hydraulic pressure is as follows : lower the fork to the ground, and stop the engine, move the control levers to each position two or three times.

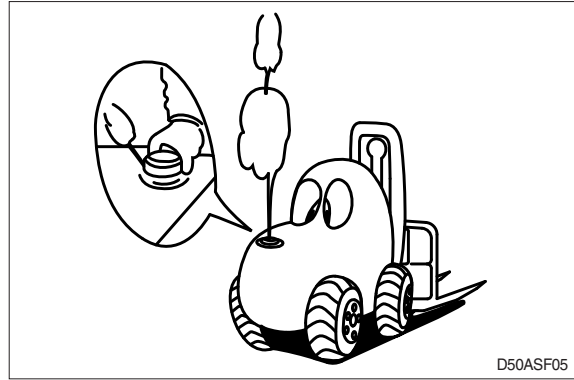

- When working on top of the truck, be careful not to lose your balance and fall.



- Hand a caution sign in the operator's compartment (For example **Do not start** or **Maintenance in progress**).

This will prevent anyone from starting or moving the truck by mistake.

▲ It is extremely dangerous to try to check the fan belt tension while the engine is running.

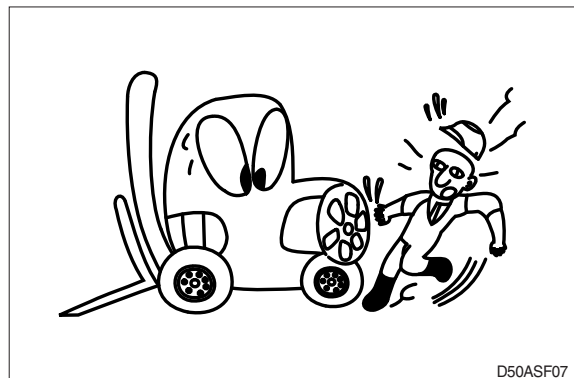

When inspecting the engine is running parts, or near such parts, always stop the engine first.

Before checking or servicing accumulator or piping, depress brake pedal repeatedly to release pressure.

- Park the truck on firm, flat ground.
Lower the fork to the ground and stop the engine.
Return each lever to **NEUTRAL** and apply the brake lock.

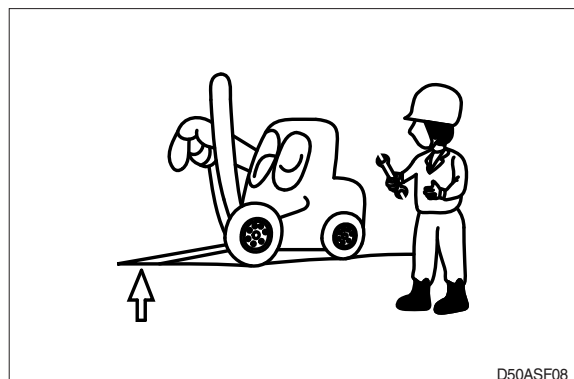

- Immediately remove any oil or grease on the floor of the operator's compartment, or on the handrail. It is very dangerous if someone slips while on the truck.

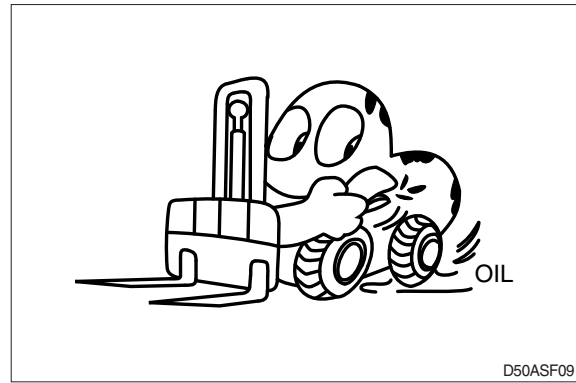

- When working with others, choose a group leader and work according to his instructions. Do not perform any maintenance beyond the agreed work.



- Always remember that the hydraulic oil circuit is under pressure. When feeding or draining the oil or carrying out inspection and maintenance, release the pressure first.



- Unless you have special instructions to the contrary, maintenance should always be carried out with the engine stopped. If maintenance is carried out with the engine running, there must be two men present : one sitting in the operator's seat and the other one performing the maintenance. In such a case, never touch any moving part.

- Thoroughly clean the truck. In particular, be careful to clean the filler caps, grease fittings and the area around the dipsticks. Be careful not to let any dirt or dust into the system.
- Always use HYUNDAI Forklift genuine parts for replacement.
- Always use the grades of grease and oil recommended by HYUNDAI Forklift. Choose the viscosity specified for the ambient temperature.
- Always use pure oil or grease, and be sure to use clean containers.
- When checking or changing the oil, do it in a place free of dust, and prevent any dirt from getting into the oil.
- Before draining the oil, warm it up to a temperature of 30 to 40 °C.
- After replacing oil, filter element or strainer, bleed the air from circuit.
- When the strainer is located in the oil filler, the strainer must not be removed while adding oil.
- When changing the oil filter, check the drained oil and filter for any signs of excessive metal particles or other foreign materials.
- When removing parts containing O-ring, gaskets or seals, clean the mounting surface and replace with new sealing parts.
- After injecting grease, always wipe off the oil grease that was forced out.
- Do not handle electrical equipment while wearing wet places, as this can cause electric shock.
- During maintenance do not allow any unauthorized person to stand near the truck.
- Be sure you fully understand the contents of the operation. It is important to prepare necessary tools and parts and to keep the operating area clean.
- When checking an open gear case there is a risk of dropping things in. Before removing the covers to inspect such cases, empty everything from your pockets. Be particularly careful to remove wrenches and nuts.
- Way to use dipstick
Push the dipstick fully into the guide, and then pull out.

Carrying out other difficult maintenance work carelessly can cause unexpected accidents. If you consider the maintenance is too difficult, always request the HYUNDAI Forklift distributor to carry out it.

GROUP 2 SPECIFICATIONS

1. MAJOR COMPONENTS

Cabin room top

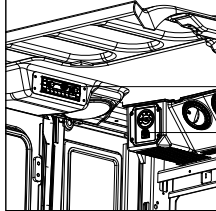

Cabin RH bottom

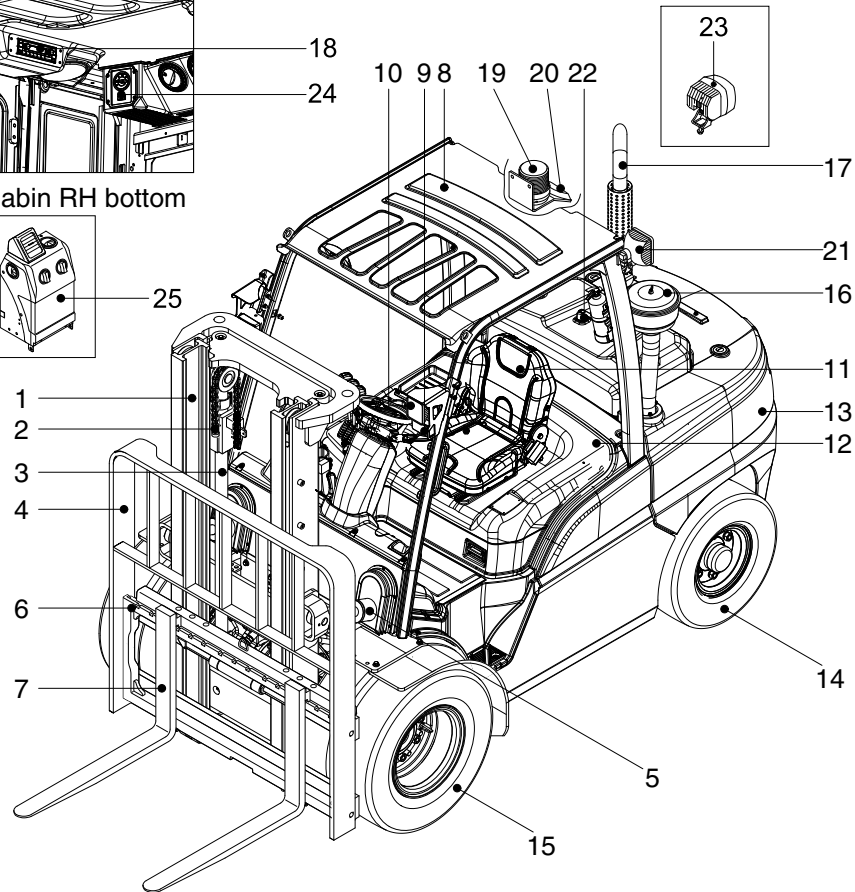
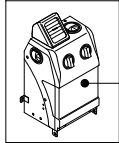

- | | | |
|--------------------|--------------------------|--------------------------------|
| 1 Mast | 10 Head lamp | 19 Beacon lamp (opt) |
| 2 Lift chain | 11 Operator's seat | 20 Camera (opt) |
| 3 Lift cylinder | 12 Bonnet | 21 Rear work lamp (opt) |
| 4 Backrest | 13 Counterweight | 22 Rear handle with horn (opt) |
| 5 Tilt cylinder | 14 Rear wheel | 23 Blue spot (opt) |
| 6 Lift bracket | 15 Front wheel | 24 Radio & USB player (opt) |
| 7 Forks | 16 Precleaner | 25 Heater (opt) |
| 8 Overhead guard | 17 Silencer | |
| 9 Turn signal lamp | 18 Air conditioner (opt) | |

35D9HDI3KY01

2. SPECIFICATIONS

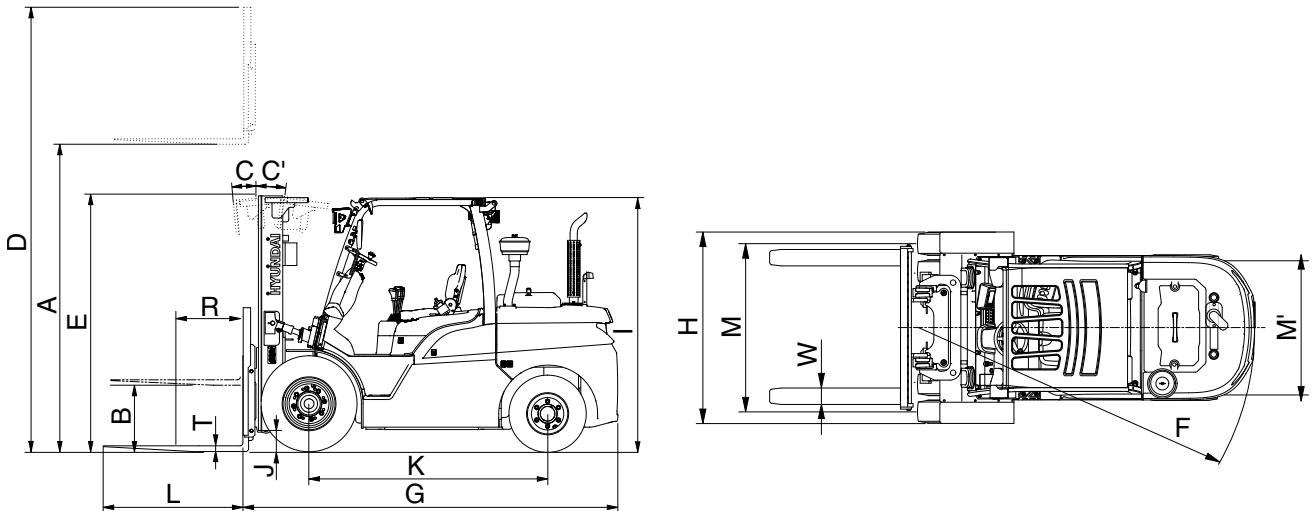

35D9VB8SP01

Model		Unit	35D-9VB	45D-9VB	50DN-9VB	
Capacity		kg (lb)	3500 (8000)	4500 (10000)	5000 (11000)	
Load center	R	mm (in)	600 (24")	←	←	
Weight (Unloaded)		kg (lb)	5851 (12899)	6860 (15124)	7264 (16014)	
Fork	Lifting height	A	mm (ft. in)	3020 (9' 11")	←	
	Free lift	B	mm (in)	120 (4.7")	←	
	Lifting speed (Unload/Load)		mm/sec (ft/min)	540/530 (106/104)	540/510 (106/100)	470/460 (92/90)
	Lowering speed (Unload/Load)		mm/sec (ft/min)	525/550 (103/108)	←	480/480 (94/94)
	L×W×T	L,W,T	mm (in)	1070×122×50 (42×4.8×2)	1220×150×50 (48×5.9×2)	1200×150×60 (47×5.9×2.4)
Mast	Tilt angle (forward/backward)	C/C'	degree	8/10	←	
	Max height	D	mm (ft. in)	4234 (13' 11")	←	
	Min height	E	mm (ft. in)	2235 (7' 4")	2220 (7' 3")	←
Body	Travel speed (Unload/Load)		km/h (mph)	30.2/27.9 (18.8/17.3)	30.2/27.9 (18.7/17.4)	30.2/27.6 (18.7/17.2)
	Max gradeability (Unload/Load)		%	19.0/47.5	16.8/37.1	15.9/34.1
	Min turning radius (Outside)	F	mm (ft. in)	2895 (9' 6")	3038 (10')	3081 (10' 1")
ETC	System set pressure		bar (psi)	210 (3050)	←	
Length to face of forks		G	mm (ft. in)	3149 (10' 4")	3284 (10' 9")	3347 (11')
Overall width		H	mm (ft. in)	1370 (4' 6")	1418 (4' 8")	←
Overhead guard height		I	mm (ft. in)	2230 (7' 4")	2220 (7' 3")	←
Ground clearance		J	mm (in)	170 (6.7")	155 (6.1")	←
Wheel base		K	mm (ft. in)	2030 (6' 8")	2100 (6' 11")	←
Wheel tread front/rear		M/M'	mm (ft. in)	1132/1140 (3' 9"/3' 9")	1120/1140 (3' 8"/3' 9")	←
Max drawbar pull (Unload/Load)		kg (lb)	4264/4459 (9400/9831)	4222/4353 (9307/9596)	4223/4358 (9310/9608)	

1) ENGINE

Item	Unit	Specification
Model	—	HDI DN03
Type	—	Vertical, 4 cycle DI
Cooling Method	—	Water cooling
Number of cylinders and arrangement	—	4 cylinders, In-line
Firing order	—	1-3-4-2
Combustion chamber type	—	Direct injection
Cylinder bore X stroke	mm (in)	98 × 113 (3.86 × 4.45)
Piston displacement	cc (cu in)	3409 (208)
Compression ratio	—	18:1
Rated gross horse power	ps/rpm	95/2300
Maximum torque at rpm	kgf · m/rpm	35.7/1600
Engine oil quantity	ℓ (U.S.gal)	12.6 (3.3)
Dry weight	kg (lb)	362 (798)
High idling speed	rpm	2500
Low idling speed	rpm	800
Rated fuel consumption	g/kWh	215
Starting motor	V-kW	12-2.7
Alternator	V-A	13.5-110
Battery	V-AH	12-100
Fan belt deflection	mm (in)	10~12 (0.40~0.47)

2) MAIN PUMP

Item	Unit	Specification
Type	—	Gear pump
Capacity	cc/rev (in ³ /rev)	46.1 (2.81) + 7.0 (0.43)
Maximum operating pressure	bar (psi)	230 (3336) + 172 (2495)
Engine idling speed (High/Low)	rpm	2450/850
Weight	kgf (lbf)	9.1 (20)

3) MAIN CONTROL VALVE

Item	Unit	Specification
Type	–	Mono-block (3spool / 4spool / 5spool)
Operating method	–	Manual (hand lever)
Maximum flow rated (Lift/Tilt)	lpm (US. gpm)	115/40 (30/11)
Main relief valve set pressure (DV1)	bar (psi)	210 (3050)
Attachment oil flow rated (Aux1/2/3)	lpm (US. gpm)	60/60/60 (16/16/16)
Attachment relief valve pressure (DV2)	bar (psi)	140~180 (2030~2610)
Weight	kgf (lbf)	3spool : 11 (24) / 4spool : 13 (29) 5spool : 15 (33)

4) STEERING UNIT

Item	Unit	Specification
Type	–	Load sensing, Non-load reaction
Capacity	cc/rev (in ³ /rev)	125 (7.63)
Steering relief valve set pressure	bar (psi)	135 (1960)
Weight	kgf (lbf)	5.5 (12)

5) PRIORITY VALVE

Item	Unit	Specification
Type	–	Load sensing, dynamic signal
Rated input flow	lpm (US.gpm)	150 (40)
Max. inlet and EF Pressure	bar (psi)	241 (3495)
Max. CF Pressure	bar (psi)	190 (2756)
Weight	kgf (lbf)	6 (13)

6) POWER TRAIN DEVICES

Item		Specification	
Torque converter	Model	KAPEC 2.25	
	Type	3 Element, 1 stage, 2 phase	
	Stall ratio	2.25 : 1	
Transmission	Type	Power shift	
	Gear shift(FWD/REV)	2/1	
	Control	Electrical single lever type	
	Overhaul ratio	FWD	1st : 2.667 2nd : 1.024
REV		1.838	
Axle	Type	Front-wheel drive type, fixed location	
	Gear ratio	11.692	
Wheels	Q'ty(FR/RR)	Single : 2/2, Double : 4/2	
	Front(drive)	Single	8.25-15-14 PR
		Double	7.50-16-12 PR
	Rear(steer)	7.00-12-14 PR	
Brakes	Travel	Front wheel, wet disk brake	
	Parking	SAHR (Spring Actuate Hydraulic Release) type	
Steering	Type	Full hydraulic, power steering	
	Steering angle	74.8° to both right and left angle, respectively	
	Relief valve pressure	135 bar (1960 psi)	

4. TIGHTENING TORQUE FOR MAJOR COMPONENTS

NO	Item	Size	kgf · m	lbf · ft	
1	Engine	Engine mounting bolt	M12 × 1.75	12.8 ± 3.0	92.6 ± 21.7
2		Engine bracket mounting bolt, nut	M10 × 1.5	6.9 ± 1.4	49.9 ± 10.1
3		Radiator mounting bolt, nut	M10 × 1.5	6.9 ± 1.4	49.9 ± 10.1
4	Hydraulic system	Hydraulic pump mounting bolt	M14 × 1.5	7.0 ± 0.5	51 ± 3.6
5		MCV mounting bolt	M 8 × 1.25	2.5 ± 0.5	18.1 ± 3.6
6		Steering unit mounting bolt	M10 × 1.5	4.0 ± 0.5	28.9 ± 3.6
7		Priority valve mounting bolt, nut	M 8 × 1.25	2.5 ± 0.5	18.1 ± 3.6
8		Tilt cylinder; rod-end bolt, nut	M14 × 2.0	15 ± 1.5	147 ± 14
9		Tilt cylinder pin; mounting bolt	M10 × 1.5	4.0 ± 1.5	28.9 ± 3.6
10	Power train system	Transmission mounting bolt, nut	M16 × 2.0	7.5 ± 1.5	54.2 ± 10.8
11		Torque converter mounting bolt	M10 × 1.5	6.9 ± 1.4	50 ± 10
12		Drive axle mounting bolt, nut	M24 × 2.0	62.5 ± 9.5	452 ± 68.7
13		Drive shaft mounting bolt	3/8-24 UNF	7.0 ± 0.7	50.6 ± 5.1
14		Steering axle mounting bolt, nut	M14 × 2.0	19.6 ± 2.9	142 ± 21
15		Front wheel mounting nut	M22 × 1.5	66.3	447
16		Rear wheel mounting nut	M22 × 1.5	66.3	447
17	Others	Counterweight mounting bolt	M30 × 3.5	100 ± 15	723 ± 108
18		Operator's seat mounting nut	M 8 × 1.25	2.5 ± 0.5	18.1 ± 3.6
19		Head guard mounting bolt	M12 × 1.75	12.8 ± 3.0	92.6 ± 21.7
20		Cabin mounting bolt	M12 × 1.75	12.8 ± 3.0	92.6 ± 21.7

5. TORQUE CHART

Use following table for unspecified torque.

1) BOLT AND NUT

(1) Coarse thread

Bolt size	8.8T		10.9T		12.9T	
	kgf · m	lbf · ft	kgf · m	lbf · ft	kgf · m	lbf · ft
M 6×1.0	0.8 ~ 1.2	5.8 ~ 8.6	1.2 ~ 1.8	8.7 ~ 13.0	1.5 ~ 2.1	10.9 ~ 15.1
M 8×1.25	2.0 ~ 3.0	14.5 ~ 21.6	2.8 ~ 4.2	20.3 ~ 30.4	3.4 ~ 5.0	24.6 ~ 36.1
M10×1.5	4.0 ~ 6.0	29.0 ~ 43.3	5.6 ~ 8.4	40.5 ~ 60.8	6.8 ~ 10.0	49.2 ~ 72.3
M12×1.75	6.8 ~ 10.2	50.0 ~ 73.7	9.6 ~ 14.4	69.5 ~ 104	12.3 ~ 16.5	89.0 ~ 119
M14×2.0	10.9 ~ 16.3	78.9 ~ 117	16.3 ~ 21.9	118 ~ 158	19.5 ~ 26.3	141 ~ 190
M16×2.0	17.9 ~ 24.1	130 ~ 174	25.1 ~ 33.9	182 ~ 245	30.2 ~ 40.8	141 ~ 295
M18×2.5	24.8 ~ 33.4	180 ~ 241	34.8 ~ 47.0	252 ~ 340	41.8 ~ 56.4	302 ~ 407
M20×2.5	34.9 ~ 47.1	253 ~ 340	49.1 ~ 66.3	355 ~ 479	58.9 ~ 79.5	426 ~ 575
M22×2.5	46.8 ~ 63.2	339 ~ 457	65.8 ~ 88.8	476 ~ 642	78.9 ~ 106	570 ~ 766
M24×3.0	60.2 ~ 81.4	436 ~ 588	84.6 ~ 114	612 ~ 824	102 ~ 137	738 ~ 991
M30×3.5	120 ~ 161	868 ~ 1164	168 ~ 227	1216 ~ 1641	202 ~ 272	1461 ~ 1967

(2) Fine thread

Bolt size	8.8T		10.9T		12.9T	
	kgf · m	lbf · ft	kgf · m	lbf · ft	kgf · m	lbf · ft
M 8×1.0	2.1 ~ 3.1	15.2 ~ 22.4	3.0 ~ 4.4	21.7 ~ 31.8	3.6 ~ 5.4	26.1 ~ 39.0
M10×1.25	4.2 ~ 6.2	30.4 ~ 44.9	5.9 ~ 8.7	42.7 ~ 62.9	7.0 ~ 10.4	50.1 ~ 75.2
M12×1.25	7.3 ~ 10.9	52.8 ~ 78.8	10.3 ~ 15.3	74.5 ~ 110	13.1 ~ 17.7	94.8 ~ 128
M14×1.5	12.4 ~ 16.6	89.7 ~ 120	17.4 ~ 23.4	126 ~ 169	20.8 ~ 28.0	151 ~ 202
M16×1.5	18.7 ~ 25.3	136 ~ 182	26.3 ~ 35.5	191 ~ 256	31.6 ~ 42.6	229 ~ 308
M18×1.5	27.1 ~ 36.5	196 ~ 264	38.0 ~ 51.4	275 ~ 371	45.7 ~ 61.7	331 ~ 446
M20×1.5	37.7 ~ 50.9	273 ~ 368	53.1 ~ 71.7	384 ~ 518	63.6 ~ 86.0	460 ~ 622
M22×1.5	51.2 ~ 69.2	370 ~ 500	72.0 ~ 97.2	521 ~ 703	86.4 ~ 116	625 ~ 839
M24×2.0	64.1 ~ 86.5	464 ~ 625	90.1 ~ 121	652 ~ 875	108 ~ 146	782 ~ 1056
M30×2.0	129 ~ 174	933 ~ 1258	181 ~ 245	1310 ~ 1772	217 ~ 294	1570 ~ 2126

2) PIPE AND HOSE (FLARE TYPE)

Hose size	Thread (PF)	Hex. across flat (mm)	Tightening torque	
			kgf-m	lbf-ft
1/4"	1/4	19	4	28.9
3/8"	3/8	22	5	36.2
1/2"	1/2	27	9.5	68.7
3/4"	3/4	36	18	130.2
1"	1	41	21	151.9
1-1/4"	1-1/4	50	35	253.2

3) PIPE AND HOSE (ORFS TYPE)

Hose size	Thread (UN/UNF/UNS)	Hex. across flat (mm)	Tightening torque	
			kgf-m	lbf-ft
1/4"	9/16-18	19	3	21.7
3/8"	11/16-16	22	5	36.2
1/2"	13/16-16	24	7	50.6
5/8"	1-14	30	12	86.8
3/4"	1-3/16-12	36	18	130.2
1"	1-7/16-12	41	23	166.4
1-1/4"	1-11/16-12	50	28	202.5
1-1/2"	2-12	58	32	231.1

4) FITTING (O-RING SEAL TYPE)

Hose size	Thread (UN/UNF)	Hex. across flat (mm)	Tightening torque	
			kgf-m	lbf-ft
1/4"	7/16-20	17	2	14.5
3/8"	9/16-18	19	3	21.7
1/2"	3/4-16	22	4	28.9
		24	6	43.4
5/8"	7/8-14	27	10	72.3
		30	12	86.8
3/4"	1-1/16-12	32	15	108.5
		36	18	130.2
1"	1-5/16-12	41	23	166.4
1-1/4"	1-5/8-12	50	28	202.5
1-1/2"	1-7/8-12	55	32	231.5

5) BAND CLAMP

Tag No.	Hose size (mm)	Band width (mm)	Tightening torque	
			kgf·m	lbf·ft
S20-15	8 ~ 14	9	0.3	2.17
S20-17	11 ~ 17			
S20-22	13 ~ 20			
S20-25	15 ~ 24			
S20-28	19 ~ 28			
S20-32	22 ~ 32	12	0.35	2.53
S20-40	26 ~ 38	9		
S20-45	32 ~ 44			
			0.42	3.04

6) BAND CLAMP (IDEAL, FLEX GEAR TYPE)

Tag No.	Hose size (mm)	Band width (mm)	Tightening torque	
			kgf·m	lbf·ft
41-212	32 ~ 54	15.9	1.1	8.0
41-262	45 ~ 67			
41-312	57 ~ 79			
41-362	40 ~ 92			
41-412	83 ~ 105			
41-462	95 ~ 117			
41-512	108 ~ 130			

6. WRENCH AND SPANEER CHART

No.	Wrench & Spanner			Thread			PIPE AND HOSE	
	inch		mm	UNF/UN	M	PF/G	ORFS (UNF/UN)	FLARE (PF)
1	-	0.050	1.3	-	-	-	-	-
2	-	0.059	1.5	-	-	-	-	-
3	1/16	0.063	1.6	-	-	-	-	-
4	5/64	0.078	2	-	-	-	-	-
5	3/32	0.094	2.4	-	-	-	-	-
6	-	0.098	2.5	-	-	-	-	-
7	7/64	0.109	2.8	-	-	-	-	-
8	-	0.118	3	-	-	-	-	-
9	1/8	0.125	3.2	-	-	-	-	-
10	9/64	0.141	3.5	-	-	-	-	-
11	5/32	0.156	4	-	-	-	-	-
12	-	0.177	4.5	-	-	-	-	-
13	3/16	0.188	4.8	-	-	-	-	-
14	-	0.197	5	-	-	-	-	-
15	13/64	0.203	5.2	-	-	-	-	-
16	7/32	0.219	5.5	-	-	-	-	-
17	15/64	0.234	6	-	-	-	-	-
18	1/4	0.250	6.4	-	-	-	-	-
19	17/64	0.266	6.8	-	-	-	-	-
20	9/32	0.281	7	-	-	-	-	-
21	5/16	0.313	8	-	-	-	-	-
22	11/32	0.344	8.7	-	-	-	-	-
23	-	0.354	9	-	-	-	-	-
24	3/8	0.375	9.5	-	-	-	-	-
25	-	0.394	10	-	-	-	-	-
26	-	-	11	-	-	-	-	-
27	7/16	0.438	11.1	-	-	-	-	-
28	15/32	0.469	12	-	-	-	-	-
29	1/2	0.500	12.7	-	-	-	-	-
30	-	-	13	-	-	-	-	-
31	17/32	0.53	13.5	-	-	-	-	-
32	-	0.55	14	7/16-20	-	-	-	-
33	9/16	0.56	14.3	-	-	-	-	-
34	19/32	0.59	15	-	-	-	-	-
35	5/8	0.63	15.9	-	-	-	-	-
36	-	-	16	-	-	-	-	-
37	21/32	0.66	16.7	-	-	-	-	-

No.	Wrench & Spanner			Thread			PIPE AND HOSE	
	inch		mm	UNF/UN	M	PF/G	ORFS (UNF/UN)	FLARE (PF)
38	-	-	17	-	M12	-	-	-
39	11/16	0.69	17.5	-	-	-	-	-
40	-	-	18	-	-	-	-	-
41	3/4	0.75	19	9/16-18	M14	G1/4	9/16-18	PF1/4
42	25/32	0.78	19.8	-	-	-	-	-
43	-	-	20	-	-	-	-	-
44	13/16	0.81	20.6	-	-	-	-	-
45	-	-	21	-	-	-	-	-
46	-	-	22	-	M16	G3/8	11/16-16	PF3/8
47	7/8	0.88	22.2	-	-	-	-	-
48	29/32	0.91	23	-	-	-	-	-
49	15/16	0.94	23.8	-	-	-	-	-
50	-	-	24	3/4-16	M18	-	13/16-16	-
51	31/32	0.97	26.4	-	-	-	-	-
52	-	-	25	-	-	-	-	-
53	1	1.00	25.4	-	-	-	-	-
54	-	-	26	-	-	-	-	-
55	1 1/16	1.06	27	7/8-14	M22	G1/2	-	PF1/2
56	-	-	28	-	-	-	-	-
57	1 1/8	1.13	28.6	-	-	-	-	-
58	-	-	29	-	-	-	-	-
59	-	-	30	-	-	-	1-14	-
60	1 3/16	1.19	30.2	-	-	-	-	-
61	-	-	31	-	-	-	-	-
62	1 1/4	1.25	31.8	-	-	-	-	-
63	-	-	32	1-1/16-12	M24	G3/4	-	-
64	-	-	33	-	-	-	-	-
65	1 5/16	1.31	33.3	-	-	-	-	-
66	-	-	34	-	-	-	-	-
67	1 3/8	1.38	35	-	-	-	-	-
68	-	-	36	1-3/16-12	M27	G3/4	1-3/16-12	PF3/4
69	1 7/16	1.44	37	-	-	-	-	-
70	1 1/2	1.50	38	-	-	-	-	-
71	-	-	39	-	-	-	-	-
72	1 9/16	1.56	39.7	-	-	-	-	-
73	-	-	40	-	-	-	-	-
74	-	-	41	1-5/16-12	M33	G1	1-7/16-12	PF1
75	1 5/8	1.63	41.3	-	-	-	-	-

No.	Wrench & Spanner		Thread			PIPE AND HOSE		
	inch	mm	UNF/UN	M	PF/G	ORFS (UNF/UN)	FLARE (PF)	
76	1 11/16	1.69	43	-	-	-	-	-
77	1 3/4	1.75	44	-	-	-	-	-
78	1 13/16	1.81	46	-	-	-	-	-
79	1 7/8	1.88	47.6	-	-	-	-	-
80	-	-	48	-	-	-	1-11/16-12	-
81	1 15/16	1.94	49.2	-	-	-	-	-
82	-	-	50	1-5/8-12	-	G1-1/4	-	PF1-1/4
83	2	2.00	50.8	-	-	-	-	-
84	-	-	51	-	-	-	-	-
85	2 1/8	2.13	54	-	-	-	-	-
86	-	-	55	1-7-8-12	-	G1-1/2	-	PF1-1/2
87	-	-	57	-	-	-	2-12	-
88	2 1/4	2.25	57.2	-	-	-	-	-
89	-	-	60	-	-	-	-	-

6. RECOMMENDED LUBRICANTS

Use only oils listed below or equivalent.

Do not mix different brand oil.

Service point	Kind of fluid	Capacity ℓ (U.S. gal)	Ambient temperature °C (°F)						
			-50 (-58)	-30 (-22)	-20 (-4)	-10 (14)	0 (32)	10 (50)	20 (68)
Engine oil pan	Engine oil	12.6 (3.3)	★SAE 5W-40						
			SAE 10W						
			SAE 10W-30						
			SAE 5W-30						
			SAE 15W-40						
			SAE 30						
Torque converter transmission	Transmission oil	18.5 (4.9)	ATF DEXRON III						
Axle	Gear oil	13 (3.4)	SHELL DONAX TD or HUYNDAI OILBANK XTEER THF 75W-80						
Hydraulic tank	Hydraulic oil	76 (20)	★ISO VG 15						
			ISO VG 32						
			ISO VG 46						
			ISO VG 68						
Fuel tank	Diesel fuel★ ¹	126 (33)	★ASTM D975 NO.1						
			ASTM D975 NO.2						
Fitting (Grease nipple)	Grease	-	★NLGI NO.1						
			NLGI NO.2						
Radiator	Antifreeze : Water	15.1 (4.0)	Ethylene glycol base permanent type (50:50)						
			★Ethylene glycol base permanent type (60 : 40)						

NOTES :

- Engine oil should be API classification CJ-4
- Change the type of engine oil according to the ambient temperature.
- When using oil of different brands from the previous one, be sure to drain all the previous oil before adding the new engine oil.

★¹ : Ultra low sulfur diesel
- sulfur content ≤ 15 ppm

★ : Cold region
Russia, CIS, Mongolia

GROUP 3 PERIODIC REPLACEMENT

For operation safety, never fail to perform periodic maintenance or make periodic replacement of the consumable parts listed in the following.

These parts may deteriorate in time and are susceptible to wear. It is difficult to estimate the degree of wear at time of periodic maintenance; therefore, even if no apparent wear is found, always replace with new parts within the prescribed period of replacement (Or earlier if trouble is found).

Note that periodic replacement has nothing to do with guarantee service.

No.	Periodical replacement of safety parts	Interval
1	Master cylinder and wheel cylinder caps dust seals	Every 1 years
2	Lift cylinder hose	Every 1 years (harsh operation) Every 2 years (normal operation)
3	Tilt cylinder hose	
4	Side shift cylinder hose	
5	Brake hose or tube	Every 2 years
6	Hydraulic pump hose	
7	Power steering hose	
8	Coolant hose and clamps	Every 2 years (harsh operation) Every 4 years (normal operation)
9	Fuel hose	
10	Packing, seal, and O-ring of steering cylinder	
11	Lift chain	Every 3 years
12	Hydraulic pump seal kit	
13	Pressure sensor	Every 5 years
14	Mast accumulator (piston type)	Every 10 years

- ※ **Replace the O-ring and gasket at the same time when replacing the hose.**
- ※ **Replace clamp at the same time if the hose clamp is cracked when checking and replacing hose.**
- ※ **Normal operation**
 - Eight hour material handling, mostly in buildings or in clean, open air on clean paved surfaces.
- ※ **Harsh operation**
 - All harsh working environment
 - Long term heavy load operation
 - High and low temperature working environment
 - Sudden change in temperature
 - Dusty or sandy working environment
 - Highly corrosive chemical working environment
 - Damp working environment